

Jens Schröter

## The laser: On the quantum materiality of media in the twentieth century

2022

<https://doi.org/10.25969/mediarep/19191>

Veröffentlichungsversion / published version

Zeitschriftenartikel / journal article

### Empfohlene Zitierung / Suggested Citation:

Schröter, Jens: The laser: On the quantum materiality of media in the twentieth century. In: *NECSUS\_European Journal of Media Studies*. #Materiality, Jg. 11 (2022), Nr. 2, S. 46–68. DOI: <https://doi.org/10.25969/mediarep/19191>.

### Erstmalig hier erschienen / Initial publication here:

<https://necsus-ejms.org/the-laser-on-the-quantum-materiality-of-media-in-the-twentieth-century/>

### Nutzungsbedingungen:

Dieser Text wird unter einer Creative Commons - Namensnennung - Nicht kommerziell - Keine Bearbeitungen 4.0/ Lizenz zur Verfügung gestellt. Nähere Auskünfte zu dieser Lizenz finden Sie hier:

<https://creativecommons.org/licenses/by-nc-nd/4.0/>

### Terms of use:

This document is made available under a creative commons - Attribution - Non Commercial - No Derivatives 4.0/ License. For more information see:

<https://creativecommons.org/licenses/by-nc-nd/4.0/>

## The laser: On the quantum materiality of media in the twentieth century

Jens Schröter

NECSUS 11 (2), Autumn 2022

<https://necsus-ejms.org/the-laser-on-the-quantum-materiality-of-media-in-the-twentieth-century/>

### Abstract

The question of the materiality of the media of the second half of the twentieth century cannot be answered without recourse to the role of quantum mechanics. Nearly all media technologies since 1945 presuppose quantum mechanics in one way or the other. The laser is especially important – this kind of coherent light, produced by stimulated emission is central to a huge plethora of very different, analog or digital, visual, audiovisual or auditory media technologies. In contrast to the role of quantum mechanics and especially the laser, the difference of analog and digital seems secondary.

**Keywords:** materiality, media, quantum mechanics, laser

For Wolfgang Hagen

### Introduction: Materiality, media, matter

When we want to discuss the materiality of media, we first have to define 'materiality' and 'media'. Both notions are difficult. Materiality seems obviously related to matter – but as the discussions in the field of so-called 'new materialism' show, and if you relate these to the work done in traditional materialism, not to speak of contemporary theoretical physics, it seems far from clear what matter exactly is.[1] For this essay, I take matter to be what physics and chemistry know about its physical and chemical properties today.[2] The reason for this decision is that these properties form the conditions of possibility of media, e.g. substances that change under the

influence of light (or other electromagnetic waves) are the conditions of possibility of photography. What are media? This is a complicated discussion too,[3] but for the sake of simplicity, I define media as all technologies that store, transmit, process, and display information (although not all four functions have to be present – the telephone can be understood as a medium although it does not store).[4] Therefore, the question of the materiality of media is: How are physical and chemical properties of matter used to store, transmit, process, and display information? This means that the changes in physical and chemical knowledge can change which types of information can be stored, transmitted, processed, and displayed. To discuss the materiality of media means to relate media history to the history of science.[5] Which discoveries in physics and chemistry led to new forms of matter (e.g. plastic) or new ways of using effects of matter (e.g. quantum effects as used in laser, which will be the main example in this essay) that allowed the construction of new media technologies? Media archaeology is an approach that does this type of research and will be the methodological guideline for this text.[6]

'Digital technologies' are especially interesting as a starting point for our discussion here, because their very name suggests that their 'digitality' is their central material property (as in contrast to 'analog technologies'). Unfortunately, that is not quite correct. The digital character addresses the question of how information is coded when it is stored (and transmitted or processed), namely in a discrete and disjunct code. But these kinds of codes are very old: languages are also structured around a repertoire of discrete (e.g. between a and b is no third character) and disjunct (e.g. a given sign must be decipherable as either a or b) characters. The German alphabet has 26 basic entities as compared to two in binary-digital computers. Money is also a discrete and disjunct code,[7] as are many numeral systems, e.g. the set of integers. The digital as such is not very specific for the media technologies we are dealing with today, although this does not mean that these do not allow new possibilities, e.g. new forms of quantification. Second, digital codes are relatively independent from the materiality of storage (transmission or processing) technologies.[8] A word can be written on paper, be constructed out of neon lights (like in many forms of advertising), sung (as in many forms of music), etc. A binary code can be stored on magnetic tape or on an optical disc (like a CD),

etc.[9] If we discuss the materiality of media, using the categories of analog or digital is not helpful, since these modes of handling information are still too far removed from the materiality and already on a higher level (although the analog storage and transmission of signals are closer to materiality than digital codes).

The decisive point of our contemporary media culture is not (or not alone) that it uses digital codes, but that there are several new technologies – materialities[10] – like the CCD or CMOS photographic sensors in smart phones, computer chips, laser light and so on that are based on a very important scientific shift in the twentieth century: the invention of quantum theory. In a paper on the media archaeology of digital photography, Wolfgang Hagen writes: 'Digitization is not the revolution of the twentieth century, but quantum mechanics, which made its technical implementation possible in the first place.'[11] The media history of the twentieth century is a history of the use of quantum mechanics for the construction of ever-new media technologies – culminating now in the much-discussed emergence of quantum computing, quantum networks, and quantum cryptography.[12] Although the role of quantum mechanics for these technologies is emphasised in their names, many older media technologies already presupposed quantum mechanics. In Karen Barad's *Meeting the Universe Halfway*, we can read:

By some estimates, 30 percent of the United States' gross national product is said to derive from technologies based on quantum mechanics. Without the insights provided by quantum mechanics, there would be no cell phones, no CD players, no portable computers.[13]

There is even a relation to analog media technologies like photography, although invented long before the development of quantum mechanics after 1900. Photochemical effects had long been observed and made useful in countless photographic experiments and then used in different forms of photography and film, but a conclusive theoretical explanation became possible only in the twentieth century with the aid of quantum mechanics.[14] Media history of the second half of the twentieth century can be rewritten focusing on quantum mechanics and the role it played in the materiality of technological media.

Obviously, this question opens up a very wide field of research that cannot be tackled in this essay. Therefore, I will focus on an especially important and interesting example: the laser. First, it is interesting that it (the laser) is never mentioned in media histories, as far as I can see. That might not be surprising, since it is normally not seen as a medium as such, but just as a light source,[15] but it is a precondition of several very different technologies that are seen as media: holography, laserdiscs, CDs, DVDs, Blu-ray, laser printers, but also the glass-fiber infrastructure that is currently built for high-speed internet or even quantum networks. That points, secondly, to the fact that if we discuss the materiality of media, we cannot handle discursively established media entities like 'holography' or the 'CD player' as separated entities. These are complex technological assemblages – although normally sealed by a 'black box' that suggests a medial unity or homogeneity where there is none: on a fundamental material level, they share technological elements like the laser, although 'holography' is an optical, visual, and analog medium[16] and the 'CD player' is an optical, acoustic, and digital medium. Moreover, some of these laser-using media are analog, some are digital, or both.[17]

In the following part of the text I want to elaborate in more detail on the archaeology of the laser and laser-including media and the complexity of their interrelations. This reconstruction will lead to a third and final part, in which I want to discuss the implications of this conceptualisation of the materiality of media.

### **The role of the laser for twentieth-century media.**

The following remarks will, of course, not include every detail of the history of the laser – that is unnecessary even if it were possible. This text is not about the history of the laser as such. It is focused on some crucial historical steps that shed light on the role the laser has had for the history of media in the second half of the twentieth century. After Planck invented quantum theory around 1900, the implications and possibilities of this new approach were discussed.[18] One important theoretical insight by Einstein was formulated in 1916: the theory of 'stimulated emission', although not by that precise name at first.[19] He postulated that there should be an amplification of light by excited atoms. An atom has a nucleus (protons and neutrons, except 'normal' hydrogen, which has only one proton in its core) and is surrounded by a 'cloud' of electrons (same number as protons in the core,

except in ions). The electrons are located on orbits, so to speak. If an atom absorbs a photon, an electron can 'jum' with that energy to a higher orbit – the atom is then 'excited'. The electron will later fall back on its former orbit and emit the absorbed energy in the form of a photon.

Now, if you shoot a photon into an already excited atom and the photon has exactly the correct energy (of the difference between the excited and unexcited atom), the excitation ends and an emission of a photon that has identical properties to the first photon is generated. You shoot one photon in and you get two identical photons out – the light is amplified. This is, in a nutshell, the process on which lasers are based. The resulting light is *coherent*, which means that it is monochromatic, its color depending on the concrete materials which are excited, and all waves are spatially and temporally in phases. It is, speaking figuratively, light marching in steps instead of the chaotic diversity of colors and phases in white light. Lasers produce a type of light that does not exist in nature, a light that has several interesting and useful properties.

It took a while until masers – a similar technology but based on microwaves instead of visible light – and then lasers were developed, based on very different materials whose atoms could be excited.[20] There is a dazzling variety of lasers today, but their stories are put aside here for the more general question of how physical (and chemical) properties of matter are used to store, transmit, process, and display information. So, how can the laser, as a result of the usage of quantum-physical properties of the interaction of light and matter, be used to store, transmit, process, and display information? There are examples for each of the four media functions. Lasers were used to achieve each of them, even quite shortly after the presentation of the first laser in 1960.

### *Storage*

This is an especially interesting case, since there are very different forms of storage media which depend on laser light. Some use the laser's unusual properties to form interference patterns; others use the energy of lasers to engrave structures into matter. Only four years after the laser was invented, the concept of holog-

raphy, which was somewhat marginal until then, gained new momentum. Its principle – ‘wave front reconstruction’ – was already invented in 1948 by Denis Gabor, but it could then only be realised in a barely convincing form, because there was no source for coherent light at that time. To understand the problem better, I want to quote a later standard presentation of holography:

In ordinary optical imaging (on a black-and-white photographic plate), only the intensity distribution of the waves coming from the object is preserved, even though these waves carry much more information – the total information being encoded in both the amplitude and the phase. The process of holography allows this phase information to be recorded also. This is done by bringing the light waves scattered from the object into interference with the waves of a reference beam, which must be coherent with the beam illuminating the object. The resulting interference pattern is recorded on the photographic plate as a hologram. To reconstruct the image, a coherent beam identical to the reference beam illuminates the hologram, which lets the observer enjoy a complete spatial image from many viewpoints.[21]

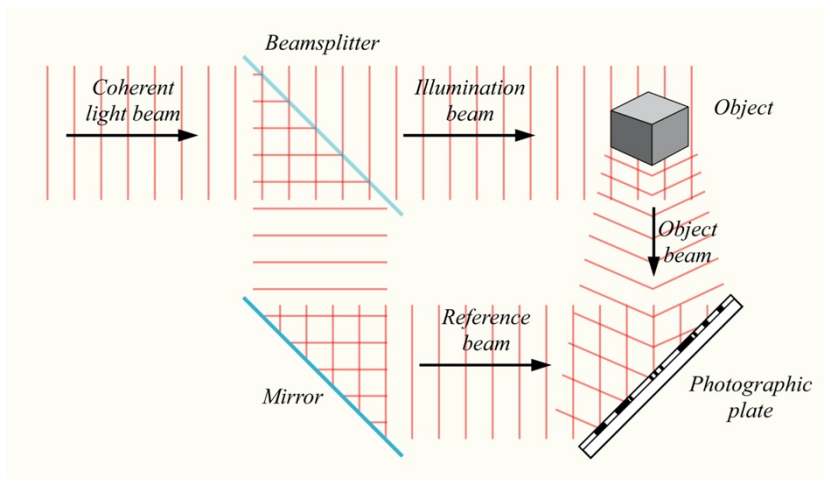

Fig. 1: Holography recording. <https://upload.wikimedia.org/wikipedia/commons/7/77/Holograph-record.svg>  
 DrBob at the English-language Wikipedia, CC BY-SA 3.0 <<http://creativecommons.org/licenses/by-sa/3.0/>>, via Wikimedia Commons.

The contingent meeting of wave front reconstruction and coherent laser light allowed the storage of full three-dimensional image information and therefore images that had never been seen before. Interestingly, however, holography could,

for several reasons, never be established as a *visual* mass medium.[22] Yet it became a mass medium in another form – but not for the dazzling display of three-dimensional visual information, but in the field of security technologies. Because of the inherent difficulties (at least for the layman) of reproducing a holographic image, holograms (and similar technologies like kinegrams) are standard anti-counterfeit technologies on money, credit cards, and ID cards. It is very difficult for counterfeiters to produce fake security holograms that look correct – a famous example was the ‘Visa dove hologram’ on Visa credit cards.[23]

Another important use of the laser in relation to storage is the role it has for *digital* optical storage media like the CD, CD-ROM, DVD, emerging since the late 1970s – while holography is analog and there have also been analog optical storage media like the short-lived laserdisc. The number of lasers produced for these purposes is enormous.[24] In storage media such as CD, CD-ROM, DVD, small lasers are used to read the data, encoded in ‘pits’ on the surface of the storage medium; or even to write them, when, for instance, a CD is ‘burned’ (this ‘burning’ means that the information cannot be erased, except in special formats like CD-RW). The ‘burning’ means that the lasers literally engrave structures into the surface. The stored data can represent images, films, music, or computer software. For the CD, a near infrared (780 nm wavelength of light) laser is used. Its reflection from the surface of the disc is measured and by this the information is read. There are several different subformats of compact discs.[26] Newer storage media like DVD and Blu-ray use lasers with shorter wavelengths (see Fig. 2), that is light getting closer to the blue side of the spectrum (that is why the Blu-ray is called as it is). The shorter the wavelength of the laser light, the smaller the pits can be made and the more information can be stored. This also means that a more scratch-resistant coating had to be developed by chemists, because now smaller defects of the surface would cause more problems. In digital storage, a direct causal link between the properties of surfaces and lasers can be found.

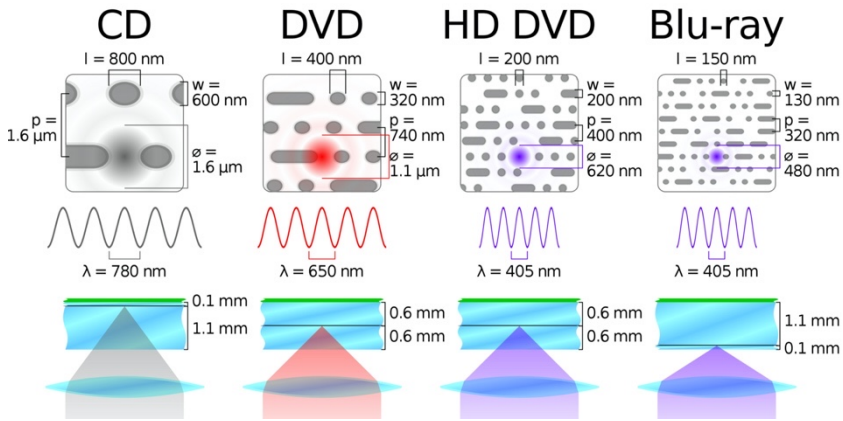

Fig. 2: Comparison between CD, DVD, HD DVD and BluRay. [https://commons.wikimedia.org/wiki/File:Comparison\\_CD\\_DVD\\_HDDVD\\_BD.svg](https://commons.wikimedia.org/wiki/File:Comparison_CD_DVD_HDDVD_BD.svg)  
 Cmglee, CC BY-SA 3.0 <<https://creativecommons.org/licenses/by-sa/3.0/>>, via Wikimedia Commons.

### Transmission

Nowadays telecommunication companies (in Europe at least) begin to build widespread glass-fiber networks, even in more rural areas.[27] Thanks to glass-fiber connections, much more data can be transmitted, the bandwidth being enormously higher than with normal cables. The first transatlantic undersea glass-fiber-cable was put into operation in 1988. As might be suspected, this form of data transmission is also based on lasers. The glass fibers transport laser light and the erbium-based optical amplifiers acting like lasers amplify the signal along the way.[28] Hecht wrote a detailed description of the material infrastructure of a transatlantic phone call. After having described how a voice on a phone is transformed into electronic and digital signals, he underlines that this signal is again transformed into light by a laser: “The electronic bit stream switches off and on a tiny *semiconductor laser no larger than a grain of salt* [italics added], turning my voice into pulses of invisible infrared light.”[29] The laser light transports the signal over long distances without high losses.

*Processing*

As Hagen already insisted, quantum mechanics is very important for modern computers, since it is the theory that explains the behavior of semiconducting materials which are the base for transistors packed together on microchips.[30] Even if quantum mechanics is not directly used in the production of microchips, there still is a special role for lasers, namely in so-called ‘photolithography’, the process with which the delicate and very small structures of microchips are produced. In a recent standard textbook, we can read:

Lithography is one of the critical processes used for the fabrication of microelectronic chips and micro/nanostructure-based electro-optical devices. The pattern structures are usually fabricated on the resist thin films and then transferred to the silicon or fused quartz substrates through the exposure and etching techniques. In the current lithographic methods, the exposure is generally based on a photochemical reaction after the resist thin film absorbs the light energy, which is referred to as light-mode lithography.[31]

Since 1982, so-called ‘excimer lasers’[32] became important for photolithography. The well known ‘Moore’s Law’, that seems to describe the rapid development of microelectronics, was made possible, according to some authors at least, only through the role played by excimer lasers.[33] The fast development and progressive miniaturisation of data-processing machines in the second half of the twentieth century (computers) directly depends on the possibility of using laser light to write ever smaller structures. In processing, the quality of the laser lies in its ability to shape materials. It is thus similar to its functioning writing traces in CDs, except that this time it functions by shaping the actual material foundation of computing technologies.

*Display*

Finally, in some forms of information display, lasers play a crucial role, especially in ‘laser printers’. This technology was developed at the beginning of the 1970s at Xerox Parc. It works basically like a photocopying machine, except that the information to be printed is written directly with the laser on the photoconductor drum (Figs 3, 4).[34]

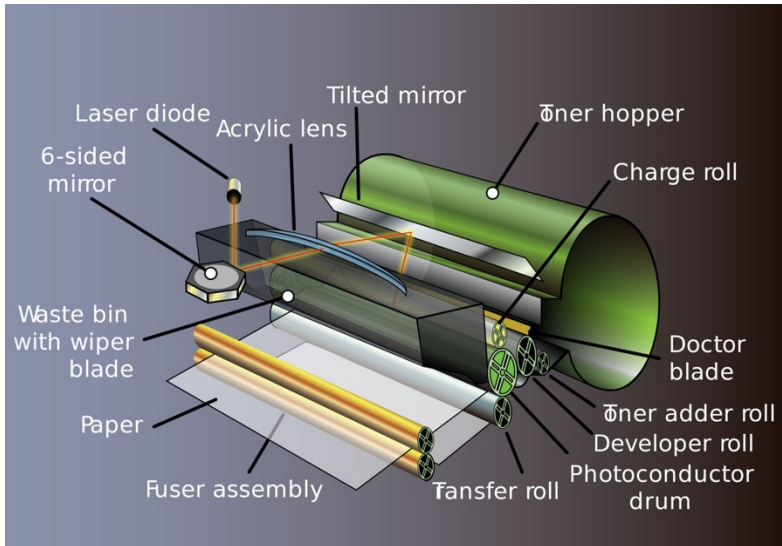

Fig. 3: Basic operational scheme of a laser printer. [https://upload.wikimedia.org/wikipedia/commons/1/1a/Laser\\_toner\\_cartridge.svg](https://upload.wikimedia.org/wikipedia/commons/1/1a/Laser_toner_cartridge.svg)  
 KDS4444, CC BY-SA 4.0 <<https://creativecommons.org/licenses/by-sa/4.0/>>, via Wikimedia Commons.

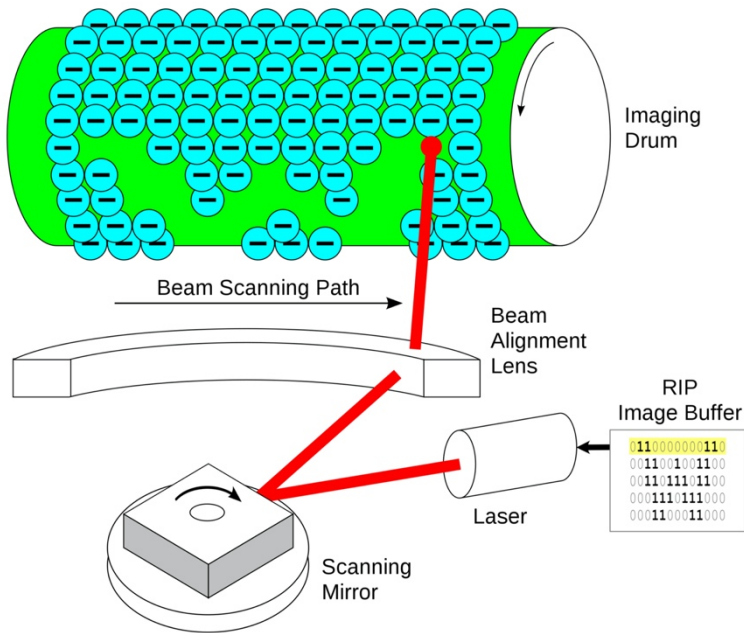

Fig. 4: Laser writing on the photoconductive drum in a laser printer. [https://upload.wikimedia.org/wikipedia/commons/1/1a/Laser\\_printer-Writing.svg](https://upload.wikimedia.org/wikipedia/commons/1/1a/Laser_printer-Writing.svg)  
 Dale Mahalko, CC BY 3.0 <<https://creativecommons.org/licenses/by/3.0/>>, via Wikimedia Commons.

The laser beam erases, so to speak, the charge of the drum where it hits it and thereby writes an electrostatic image. This allows it to produce an image using the toner, which sticks to the charged parts of the photoconductor drum (Fig. 4). This toner-image can then be printed on paper and fixated via heat (the ‘fuser assembly’ in Fig. 3). There are different ways of doing this, but these details are not important for our discussion here. Suffice to say that lasers can change material media by changing their electrostatic charge; an important step beyond the more fixed procedures of printing media. With the fast, fluent form they provide, they have become indispensable for cheaply printing information on paper. They do this by changing the material properties of the drum.

### **Media-theoretical conclusions**

Given the diversity of usages of the laser and its indispensability for the history of modern media, it is really surprising that lasers were first seen as a ‘solution looking for a problem’.[35] There were only a few imagined uses for the new form of light. Unsurprisingly, the military conceptualised lasers mainly as a new type of weapon,[36] as can be seen in an early history of the laser from 1964 that was already published in 1965 in a German translation with the sensationalist title *Todesstrahlen?* or, in English, ‘Death rays?’[37] Also in 1964, the movie *Goldfinger* (Guy Hamilton) featured a special effect of the brand-new technology, once to unsuccessfully kill James Bond and once more, later, to destroy the heavy doors leading into Fort Knox. There was also the idea to use lasers for communicative purposes, e.g. secure military communication. It had, however, not been established that *low-power* lasers could have important uses in storing, transmitting, processing, and displaying information in more vernacular contexts. In short: new technological materialities do not come with clear ideas of how to use them. The case of holography shows that it is sometimes a fortuitous meeting with another development (in that case: wave-front reconstruction) that allows the existence of a new medium. A similar case is laser printing, in which the technology of electrostatic xerography crossed paths with laser light in the early seventies (when lasers had become cheaper and smaller). The materiality of media is the result of a historically contingent assemblage of different technologies.

Therefore, focusing on the role of quantum mechanics and especially stimulated emission – the laser – also shows a lower level of materiality that is transversal to distinctions like analog/digital. While the storage of information in holography or laserdisc is analog, it is rather digital in technologies such as CD and DVD – the laser just writes and transmits information regardless of its form. Although it is light, it also transmits acoustic or audiovisual information. Without quantum technology, many of our contemporary media technologies would not exist, although some older technologies like the record player are exceptions to this rule.[38] The quantum properties of media materiality are more fundamental than the question of analog/digital.[39] Therefore, the contemporary dissemination of digital technologies should be called the ‘quantum mechanisation’ and not ‘digitisation’ of society. The already fundamental digitality of society, its grounding in discrete and disjunct codes like language, money, etc., as described by Beniger and more recently Nassehi,[40] becomes technologically externalised and accelerated by quantum materialities that allow the construction of digital technologies. This is especially visible in the economic repercussions of these quantum technologies. Computers accelerate the processing of data, with CDs and DVDs information can be stored in a stable way and sold as a commodity; glass-fiber networks accelerate the transmission of data; and as Marx already analysed, acceleration is inherent in capitalist production:

The expansion and contraction of the circulation time hence acts as a negative limit on the contraction or expansion of the production time, or of the scale on which a capital of a given magnitude can function. The more that the circulation metamorphoses of capital are only ideal, i.e., the closer the circulation time comes to zero, the more the capital functions, and the greater is its productivity and self-valorization.[41]

Besides the already discussed microchip processing or CD-ROM storage, another important example for economic optimisation is barcode readers, which also are mostly based on lasers.[42] They accelerate the throughput of selling and holographic elements (produced with lasers) securitise money and credit cards, some of the central media of capitalism.[43] This clearly shows that the openness of the new technology of the laser, the ‘solution looking for a problem’, found (at least some of) its problems in the challenges of capitalist economy. This is in a way not surprising, but it proves that the materiality of media is a ‘compromise between

engineers and marketing experts'.[44] The results of science are functionalised first and most often by the military, and then later used in commercial products, integrated in capitalist circulation.[45] Nothing in the laser is 'inherently' capitalist, but the ways it gets combined with other technologies to form the materiality of media like holography or optical discs have their use for accumulation.

That being said, quantum mechanics is not only the basis for most media technologies of the second half of the twentieth century, it also changes discourse. 'New materialism', in particular, explicitly refers to it with its notion that matter is based on contemporary physics. In the foreword to their excellent anthology, Coole & Frost note, after a synopsis of some facets of the standard model of particle physics, 'that theoretical physics' understanding of matter is now a long way from the material world we inhabit in our everyday lives and that it is no longer tenable to rely on the obsolete certainties of classical physics as earlier materialists did.'[46] This implies that new materialism has developed an evolving understanding of material properties in which 'forces, energies, and intensities (rather than substances) and complex, even random, processes (rather than simple, predictable states) have become the new currency'.[47] This is, they imply, particularly relevant for cultural formations and political decision-making, with science concepts potentially reconfiguring 'our models of society and the political'.[48] All of this seems to suggest that our quantum – and particularly our laser-based media environment – foregrounds new notions that change the way we conceptualise our realities.[49] And these changes, whichever shape they may take, seem to be more important than our fixation on the digital. There are basically two ways to react to the 'new conceptions of matter' provided by quantum materiality in cultural and media theory: (a) we can use these insights to criticise established notions; and (b) we can import notions from quantum mechanics into cultural and media studies – although this is always risky, since '[m]etaphors borrowed [...] from physics break down very fast'.[50] I will now discuss these two options shortly before turning to the laser again.

*(a)*

Hagen, who writes not explicitly about lasers but on the media archaeology of digital photography, argues that quantum mechanics is 'imageless' in the sense that

it mathematically describes entities and processes, which have no similarity to things we know from our everyday world and that we therefore cannot imagine at all.[51] From this, he concludes, to put it simply, that the images produced by quantum-electronic sensors in smartphones are not images. The notion of 'image' is, according to Hagen, disrupted by quantum mechanics and no longer appropriate for the phenomena we call 'digital images.'

Although this is an interesting and provocative claim, it is problematic for three reasons. First, quantum phenomena like laser light are not only used for producing or distributing images, but also for sound. How can the supposed imageless character of quantum mechanics relate to sound reproduction given that sound is imageless from the very beginning? It seems implausible that the imageless character of quantum mechanics behind media technologies changes the character of digital images, but not of digital sound.

Second, Hagen's argument that the images produced by image sensors like CCDs[52] are not images is surprisingly similar to an argument by Claus Pias, who argues that the notion of 'digital images' makes no sense, since these images are analog representations of a numerical, digital code.[53] Pias doubts that images can be described as digital, while Hagen argues that the phenomena we produce with CCDs cannot be called images. The problematic character of digital images seems to be no genuine insight resulting from the reflection on quantum mechanics alone.

Third, and most important, these arguments disputing the imaginary character of digital images are highly counter-intuitive, since digital images, often in the form of digital photography, are of course, routinely used as images. People using image sensors in their smartphones understand the results as images and carry on the same (or at least similar) practices with images that were already in place with analog images. A striking example is family photography. Sure, most people do not compose family albums materially any more (although this practice surely still exists), but rather put their family photographs online. Yet, the practice of family photography and its associated cultural values did not disappear. The shift to digital cameras caused, at least in this case, no big shift in practices.[54] Hagen itself

admits that.[55] I would argue that this precisely shows that the quantum materiality is more important than the analog/digital distinction: similar quantum effects used in analog and in digital photographic recording[56] allow the recording of traces of light and therefore photographic practices. The quantum technology of lasers exhibits the same transversal character towards the analog/digital-distinction; it can be used to record and read analog (Laserdisc) and digital (CD, DVD, Blu-ray) traces.

*(b)*

There are, in the contemporary discourse of cultural and media studies, at least two notions imported from quantum mechanics: ‘entanglement’ and ‘diffraction’, which became widespread through the work of Donna Haraway and Karen Barad. I will focus here, for the sake of clarity and brevity, on diffraction.[57] Haraway used the notion already in 1997:

Reflexivity has been much recommended as a critical practice, but my suspicion is that reflexivity, like reflection, only displaces the same elsewhere, setting up the worries about copy and original and the search for the authentic and really real. [...] Diffraction is an optical metaphor for the effort to make a difference in the world.[58]

The idea is to replace optical metaphors used in philosophy (and other critical discourses) to describe critical, epistemological processes – reflection and reflexivity – by another optical metaphor: diffraction. The older metaphors are suspected to be centered around the model of the mirror (also a certain type of materiality) and, thereby, to be caught in a process of doubling ‘the same elsewhere’. ‘Diffraction, the production of difference patterns, might be a more useful metaphor for the needed work than reflexivity.’[59] I do not want to discuss the usefulness of this diffractive approach,[60] but simply to stress that Barad relates it more closely and in more detail to physics. She underlines that it is a phenomenon that happens to waves of all kinds, either when they encounter an obstacle and flow around or through a hole in it (in older parlance: diffraction proper) or when two waves with the right properties overlap (in older parlance: interference).[61] To be sure, she uses diffraction and interference interchangeably.[62] These phenomena were

first discussed in relation to the wave nature of light – but later, as quantum mechanics made clear that particles also behave like waves (and the other way round), it turned out that diffraction can also happen to matter.

At this point, we can remember that, as seen above (Fig. 2), the ‘interference or diffraction patterns’[63] produced by laser beams were recorded to form holograms. Therefore, when Haraway writes, ‘What we need is to make a difference in material-semiotic apparatuses, to diffract the rays of technoscience so that we get more promising *interference patterns on the recording films* of our lives and bodies’,[64] she speaks of holography and therefore of laser light, because without the coherent light of laser no interference or diffraction patterns could be recorded. Similarly, Barad explains diffraction with the example of an image of a razor blade ‘illuminated by a monochromatic light source’.[65] Although laser light is not mentioned, it is also monochromatic light. Diffraction patterns are not visible with normal white light: ‘If we use a white frosted light bulb instead of a point source to illuminate the razor blade [...] each wavelength of the light from every point of the bulb forms its own diffraction pattern, but the patterns overlap so much that we can’t see any individual pattern.’[66] The same reason explains why holography was only possible after the invention of the laser.

This short discussion of Hagen, Barad, and Haraway might not show how ‘new conceptions of matter might reconfigure our models of society and the political’,[67] as Coole and Frost said above. But it shows that questions and notions of quantum mechanics entered cultural and media studies a century after quantum mechanics allowed the development of new media technologies that changed the mediascape. One of the most important technologies was the laser, that is even (as shown above) a fundamental condition for the development of ever smaller and faster computers. It is the laser that directly influenced the discourses of Haraway and Barad.

To conclude, we can state that the laser and its media-historical, economic, and discursive repercussions have been underestimated. The laser is one of the central material underpinnings of media culture (and its theoretical reflections – or should we say diffractions?) since 1960. Studying aspects of this history makes

clear that the shift from analog to digital is not the central (or at least, not the only important) change in media history. The question of materiality is located on a deeper level than the question of the forms used to store, transmit, process, or display signals.

### Author

Jens Schröter, Prof. Dr., is Chair of Media Studies at the University of Bonn since 2015. Director (together with Prof. Dr. Anna Echterhölter; PD Dr. Sudmann, and Prof. Dr. Alexander Waibel) of the VW-Main Grant How is Artificial Intelligence Changing Science? (Start: 1.8.2022, 4 Years); Winter 2014/15: Senior-fellowship at the research group 'Media Cultures of Computer Simulation', Summer 2017: Senior-fellowship IFK Vienna, Austria. Winter 2018: Senior-fellowship IKKM Weimar. Winter 2021/22: Fellowship, Center of Advanced Internet Studies. Recent publications include *Medien und Ökonomie* (Wiesbaden: Springer, 2019); (together with Christoph Ernst) *Media Futures. Theory and Aesthetics* (Basingstoke: Palgrave, 2021). [www.medienkulturwissenschaft-bonn.de](http://www.medienkulturwissenschaft-bonn.de) / [www.theorie-der-medien.de](http://www.theorie-der-medien.de) / [www.fanhsiu-kadesch.de](http://www.fanhsiu-kadesch.de)

### References

- Barad, K. *Meeting the universe halfway: Quantum physics and the entanglement of matter and meaning*. Durham: Duke University Press, 2007.
- \_\_\_\_\_. 'Diffracting diffraction: Cutting together-apart', *Parallax*, Vol. 20, No. 3, 2014: 168-187.
- Basting, D., Djeu, N., and Jain, K. 'Historical review of excimer laser development' in *Excimer laser technology*, edited by D. Basting and G. Marowsky. Berlin-Heidelberg: Springer, 2005: 8-21.
- Beniger, J. *The control revolution: Technological and economic origins of the information society*. Cambridge-London: Harvard University Press, 1986.
- Bromberg, L. *The laser in America, 1950-1970*. Cambridge-London: MIT Press, 1991.
- Carroll, J. *Todesstrahlen? Die Geschichte des Laser* [sic]. Frankfurt a. M.: Ullstein, 1965.
- Coole, D. and Frost, S. *New materialisms: Ontology, agency, and politics*. Durham-London: Duke University Press, 2010.
- Cramer, F. 'What is 'post-digital'?' in *Postdigital Aesthetics: Art, Computation and Design*, edited by D. Berry and M. Dieter. Basingstoke: Palgrave Macmillan 2015: 12-26.
- Cruz, E. and Lehmuskallio, A (eds). *Digital photography and everyday life: Empirical studies on material visual practices*. London-New York: Routledge, 2016.
- De Landa, M. *A thousand years of nonlinear history*. Cambridge-London: MIT Press, 2005.

## THE LASER: ON THE QUANTUM MATERIALITY OF MEDIA IN THE TWENTIETH CENTURY

- Galison, P. *Image and logic: A material culture of microphysics*. Chicago: Chicago University Press, 1997.
- Goldberg, D. *The standard model in a nutshell*. Princeton-London: Princeton University Press, 2017.
- Goodman, N. *The languages of art: An approach to a theory of symbols*. Indianapolis et al: Bobbs-Merrill, 1968.
- Hagen, W. 'Die Entropie der Fotografie: Skizzen zu einer Genealogie der digital-elektronischen Bildaufzeichnung' in *Paradigma Fotografie: Fotokritik am Ende des fotografischen Zeitalters*, Vol. 1, edited by H. Wolf. Frankfurt a. M.: Suhrkamp, 2002: 195-225.
- Haraway, D. *Modest\_Witness@Second\_Millennium.FemaleMan@\_Meets\_OncoMouseTM*, second edition. New York-London Routledge, 2018.
- Hecht, J. *City of light: The story of fiber optics*. Oxford: Oxford University Press, 1999.
- \_\_\_\_\_. *Understanding lasers*, third edition. Hoboken: John Wiley, 2008.
- Heine, W. *Disc phonograph record playback by laser generated diffraction pattern*. US Patent 3, 992, 593, 16 November 1976.
- Hoffmann, S. *Geschichte des Medienbegriffs*. Hamburg: Felix Meiner, 2002.
- Hölscher, T. 'Nelson Goodmans Philosophie des Analogen und des Digitalen' in *Hyperkult II. Zur Ortsbestimmung analoger und digitaler Medien*, edited by M. Warnke, W. Coy, and G Tholen. Bielefeld: transcript, 2005: 111-122.
- Höltgen, S (ed.). *Medientechnisches Wissen: Band 1: Logik, Informationstheorie*. Berlin-Boston: DeGruyter, 2017.
- \_\_\_\_\_. *Medientechnisches Wissen: Band 2: Kybernetik, Programmieren, Informatik*. Berlin-Boston: DeGruyter, 2018.
- \_\_\_\_\_. *Medientechnisches Wissen: Band 3: Mathematik, Physik, Chemie*. Berlin-Boston: DeGruyter, 2020.
- House, J. *Inorganic chemistry*, third Edition. London et al: Academic Press, 2019.
- James, T. 'A quantum theory of the latent photographic image', *Journal of Chemical Physics*, Vol. 2, March 1934: 132-135.
- Jammer, M. *The conceptual development of quantum mechanics*. Los Angeles: Tomash, 1989.
- Johnston, S. *Holographic visions: A history of new science*. Oxford: Oxford University Press, 2006.
- Ju, G. et al. 'High density heat-assisted magnetic recording media and advanced characterization – progress and challenges', *IEEE Transactions on Magnetics*, Vol. 51, No. 11, 2015: 1-9.
- Kittler, F. *Draculas Vermächtnis. Technische Schriften*. Leipzig: Reclam, 1993.

- \_\_\_\_\_. 'Gleichschaltungen. Über Normen und Standards der elektronischen Kommunikation' in *Geschichte der Medien*, edited by M. Faßler and W. Halbach. München: UTB, 1998: 255-268.
- Kleppner, D. 'Rereading Einstein on radiation', *Physics Today*, Vol. 58, No. 2, February 2005: 30-33.
- Kompaan, K. and Kramer, P. 'The Philips "VLP" system' in *Origins and successors of the compact disc: Contributions of Philips to optical storage*, edited by H. Peek et al. Dordrecht: Springer Netherlands, 2009: 25-30.
- La Fontaine, B. 'Lasers and Moore's law', *SPIE Professional*, 1 October 2010: <http://spie.org/x42152.xml> (accessed on 11 July 2022).
- Latour, B. *Reassembling the social: An introduction to actor-network-theory*. Oxford: Oxford University Press, 2005.
- Marx, K. *Capital. A critique of political economy*, vol. 2. London: Penguin, 1993.
- Mazzucato, M. *The entrepreneurial state: Debunking public vs. private sector myths*. London: Anthem Press, 2014.
- McLuhan, M. *Understanding media: The extensions of man*. Cambridge- London: MIT Press, 1994 (orig. in 1964).
- Mitchell, J. and Mott, N. 'The nature and formation of the photographic latent image', *Philosophical Magazine*, Vol. 2, No. 21, 1957: 1149-1170.
- Mort, J. *The anatomy of xerography: Its invention and evolution*. Jefferson et al: MacFarland, 1989.
- Nassehi, A. *Muster. Theorie der digitalen Gesellschaft*. München: Beck, 2019.
- Orrell, D. 'A quantum theory of money and value', *Economic Thought*, Vol. 5, No. 2, 27 September 2016: 19-28.
- Parikka, J. *What is media archaeology?* Cambridge: Polity Press, 2012.
- Peek, H. 'The emergence of the compact disc', *IEEE Communications Magazine*, Vol. 48, No. 1, January 2010: 10-17.
- Pias, C. Das digitale Bild gibt es nicht. Über das (Nicht-)Wissen der Bilder und die informatische Illusion, <https://www.zeitenblicke.de/2003/01/pias/pias.pdf> (accessed on 11 July 2022).
- Schröter, J. *3D: History, theory and aesthetics of the transplane image*. New York: Bloomsbury, 2014.
- \_\_\_\_\_. 'Digitale Medien und Methoden. Jens Schröter zur Medienarchäologie der digitalen Medien', *Open Media Studies*, 29 October 2020: <https://mediastudies.hypotheses.org/2421> (accessed on 11 July 2022).
- Schröter, J., Ernst, C., and Warnke, M. 'Quantum computing and the analog/digital distinction', *Grey Room*, No. 86, February 2022: 28-49.
- Seidel, R. 'From glow to flow: A history of military laser research and development',

*Historical Studies in the Physical and Biological Sciences*, Vol. 18, No. 1, January 1987: 111-147.

Simonyi, K. *A cultural history of physics*. Boca Raton: CRC Press, 2012.

Steyerl, H. 'Proxy politics. Signal and noise', *e-flux journal*, #60, 2014: <https://www.e-flux.com/journal/60/61045/proxy-politics-signal-and-noise/> (accessed on 11 July 2022).

Stoljar, D. 'Physicalism' in *Stanford encyclopedia of philosophy*, 25 May 2021: <https://plato.stanford.edu/entries/physicalism/> (accessed on 11 July 2022).

Wei, J. *Laser heat-mode lithography: Principle and methods*. Singapore: Springer Nature, 2019.

Young, H. and Freedman, R. *Sears and Zemansky's university physics with modern physics*, 13th edition. Boston et al: Addison Wesley, 2012.

## Notes

- [1] On 'new materialism' see Coole & Frost 2010; on the complex history of very different forms of 'materialism' and 'physicalism' see Stoljar 2021.
- [2] On the contemporary 'standard model' of forces and matter in physics see Goldberg 2017; on inorganic chemistry see House 2019, and for a very concise introduction to many of these topics, especially for scholars in media studies, see the three volumes Höltgen 2017, 2018, 2020.
- [3] See Hoffmann 2002.
- [4] See Kittler 1993, p. 8. Kittler does not mention the 'display' of information, but I think it should be added.
- [5] The situation is even more complex and recursive since the history of science is not only a condition for the history of media, but also the development of new media is a condition for further scientific progress, see e.g. the history of the material culture of particle physics by Galison 1997.
- [6] See Schröter 2020 and for a wider discussion Parikka 2012.
- [7] Goodman 1968, p. 152 and pp. 159-164. For a concise exposition of Goodman's approach towards analog and digital see Hölscher 2005.
- [8] That does not mean that digital codes are 'immaterial', but only that they can be transferred without loss – in principle, although in reality often forms of lossy compression are used – and noise from one materiality to another (there would be no problem with illegal file sharing if it were otherwise). It also does not mean that there is not an extractive economy (invisible work, exploitation of rare materials in the global south etc.) in the background of digital technologies – but these correct facts have nothing to do with the question if digital codes can be reproduced in different materialities.
- [9] It is a difficult and interesting problem to contrast this with analog signals, since these can of course also be transferred from one materiality to another (music on vinyl can be recorded on analog tape for example), but in that case you have to fight with noise or hiss (at least more than with digital technologies, although these of course have other disturbances and malfunctions).

- [10] Insofar technology is structured matter according to known laws of physics and chemistry (and also biology, which, at the moment, plays only a little role for media technology).
- [11] Hagen 2002, p. 222: 'Nicht die Digitalisierung ist die Revolution des zwanzigsten Jahrhunderts, sondern die Quantenmechanik, die ihre technische Implementierung erst ermöglicht hat.' (my translation)
- [12] See Schröter & Ernst & Warnke 2022.
- [13] Tim Folger cited in Barad 2007, p. 252.
- [14] See as an early example James 1934.
- [15] Although McLuhan (1994, p. 8) argued that light is the medium per se.
- [16] On holography see Schröter 2014, ch. 9. On the difference between optical media (those that presuppose the knowledge of optics) and visual media (producing output visible to the eye), *ibid.*, pp. 320-327.
- [17] To be more precise: all digital technologies are also analog technologies, since their output has to be analog, while analog technologies do not need to include digital elements (but can).
- [18] On the history of quantum mechanics see Jammer 1989.
- [19] See Hecht 2008, pp. 29-41. See Kleppner 2005.
- [20] See Bromberg 1991.
- [21] Simonyi 2012, p. 496. On the history of holography see Johnston 2006.
- [22] Holographic images are difficult to produce, difficult to watch, are not reproducible, and holographic cinema is exceedingly difficult to produce. Moreover, holography's informational density is very high, so that electronic and/or digitalised holographic information would be very hard to transmit, even using today's glass-fiber networks. The notion of 'hologram' is nowadays routinely misused for high-definition computer graphics or video projected in open space on different kinds of nearly invisible screens, e.g. in the much-discussed new ABBA-show in London. See <https://www.mirror.co.uk/3am/celebrity-news/what-abba-voyage-how-hologram-27079797> (accessed on 26 July 2022).
- [23] See <https://usa.visa.com/dam/VCOM/global/support-legal/documents/dovevbn.pdf> (accessed on 26 July 2022).
- [24] On the analog 'VLP' laserdisc technology by Phillips see Kompaan & Kramer 2009. New storage technologies based on the use of laser light are HAMR (Heat Assisted Magnetic Recording), which is available since 2021 and HDMR (Heated Dot Magnetic Recording), that will not be available before 2025 or even later. Both allow enormously higher storage capacities as compared to standard hard discs, see Ju et al. 2015.
- [25] Hecht 2008, p. 344.
- [26] See Peek 2010.
- [27] See e.g. the recent campaign of Deutsche Telekom: <https://www.telekom.de/netz/glasfaser> (accessed on 26 July 2022).
- [28] Hecht 1999, p. 214, see also pp. 239-256.
- [29] Hecht 1999, p. 4.
- [30] Hagen 2002, p. 204: 'Es ist die Quantenmechanik der Halbleiterphysik, die seither jedes Gerät unseres Alltags beherrscht, aber ebenso auch alle Waffenarten. Die Quantenmechanik ist diejenige Elementarwissenschaft, mittels deren die Herzstücke aller unserer Computer gefertigt werden. Als Wissenschaft vom Bau der Chips beherrscht die Quantenmechanik – die Welt.'; 'It is the quantum mechanics of semiconductor physics that has dominated every device of our everyday life ever

- since, but also all types of weapons. Quantum mechanics is the elementary science by means of which the heart of all our computers is made. As the science of building chips, quantum mechanics rules the world.' (my translation)
- [31] Wei 2019, p. 1
- [32] See Basting & Djeu & Jain 2005. See also Hecht 2008, pp. 211-212.
- [33] See La Fontaine 2010.
- [34] See Hecht 2008, pp. 347-350. On the history of photocopying – 'xerography' – which is, besides laser printing, the only media technology that uses the effect of electrostatic charge, see Mort 1989.
- [35] Hecht 2008, p. xi, 15, 340.
- [36] See Seidel 1987.
- [37] Carroll 1965.
- [38] There has been the idea to read conventional vinyl with laser light, see Heine 1976. But this technology could not establish itself, since on the one hand, although avoiding rumble and tear by not touching the record, it still sounded like classical vinyl, because it 'played' every speckle of dust on the disc, instead of – as a conventional record player would do – pushing it away with the needle. On the other hand, soon the CD would emerge, giving a better sound (after some initial problems).
- [39] That the analog/digital is perhaps only one distinction but not the most important one (at least in the way it is conceptualised now) becomes visible in an emerging discourse on 'post-digitality' (see amongst many other papers, Cramer 2015). The emerging technologies of quantum computation also transgress the analog/digital-distinction (see Schröter & Ernst & Warnke 2022).
- [40] See Beniger 1986 and Nassehi 2019.
- [41] Marx 1993, p. 203.
- [42] See Hecht 2008, pp. 342-344.
- [43] See Johnston 2006, pp. 372-377.
- [44] Kittler 1998, p. 261 (my translation).
- [45] See Mazzucato 2014.
- [46] Coole & Frost 2010, p. 12. On the standard model see Goldberg 2017.
- [47] Coole & Frost 2010, p. 13.
- [48] Ibid.
- [49] There is already a 'quantum theory of money and value', see Orrell 2016.
- [50] Latour 2005, p. 24. On the possibilities and problems of importing notions from the natural sciences see also De Landa 2005.
- [51] Hagen 2002, p. 219: 'Modell-Bildungen in der Quantenmechanik sind von rein operationaler Bildlichkeit. Und sie sind es nicht deswegen, weil von Neumanns Quantenmechanik einfach nur bilderlos wäre. Das ist sie allerdings völlig'; 'Model formations in quantum mechanics are of purely operational pictoriality. And they are not because von Neumann's quantum mechanics is simply only imageless. However, it is completely [imageless]'. (my translation)
- [52] CCD means 'charged coupled device' and is a technology developed around 1970 that later became the base of imaging technologies. In today's cameras so-called CMOS-elements are often used, but anyway the image sensors of today are based on the use of quantum mechanical effects.
- [53] See Pias 2003, n. p.: 'Das digitale Bild gibt es nicht. [...] Was es gibt, sind ungezählte analoge Bilder, die digital vorliegende Daten darstellen. [...] Eine Sounddatei kann als Text angezeigt werden, eine Textdatei kann als Bild betrachtet werden, und eine

- Bilddatei kann als Sound abgespielt werden. Die Information bleibt gleich. Information hat keine Materialität und sie hat keine Bedeutung. Zugleich aber tritt sie immer nur in Formen gebunden in Erscheinung'; 'The digital image does not exist. [...] What there is, are uncounted analog images, which represent digitally present data. [...] A sound file can be displayed as text, a text file can be viewed as an image, and an image file can be played as sound. The information remains the same. Information has no materiality and it has no meaning. At the same time, however, it always appears bound only in forms' (my translation). See also Steyerl 2014.
- [54] For interesting studies in practices with digital photography, see Cruz & Lehmuskallio 2016.
- [55] Hagen 2002, p. 195: 'Ganz praktisch gefragt, was hat Fotografieren durch digitale Bildproduktion verloren? Wenig, vielleicht hier und da gar gewonnen [...].'; 'In practical terms, what has photography lost through digital image production? lost? Little, perhaps even gained here and there' (my translation).
- [56] See Mitchell & Mott 1957, who speak, while explaining the photographic process, explicitly of 'positive holes' (p. 1149 and passim) operative in the (chemical-)photographic process on a quantum level. Hagen 2002, p. 221 speaks of the same effects in relation to digital image-sensors and insists that these moving, positive holes are a primary example for a strictly operational quantum metaphor that corresponds to no imaginable reality.
- [57] On entanglement, see Barad 2007, pp. 273-352. See Simonyi 2012, p. 485.
- [58] Haraway 2018, p. 16. The book was originally published in 1997.
- [59] Haraway 2018, p. 34. See Barad 2007, p. 71 for a similar argument.
- [60] See Barad 2014 for an interesting example.
- [61] Barad 2007, pp. 74-78.
- [62] Ibid., pp. 80-81.
- [63] Ibid., p. 78.
- [64] Haraway 2018, p. 16 (my emphasis).
- [65] Barad 2007, p. 76.
- [66] Young & Freedman 2012, p. 1191.
- [67] Coole & Frost 2010, p. 13.